

Front Suspension:

Ride Height: _____
 Camber: _____
 Toe: _____
 Anti-Roll Bar: _____
 Arm Type: _____
 Wheelbase Shim: _____
 Wheel Hex: _____
 Caster Block: 8° 9° 10°
 Chassis Brace: Plastic Carbon
 Top Plate Brace: Yes No
 Front Axles: CVA DCV
 Notes: _____



Front Chassis Brace Screws: _____

Ball Stud Spacing: _____



Arm Mount A: 1° 0.5°



Arm Mount B: 1° 0.5°

Diff Height:

+3

+2

+1

0

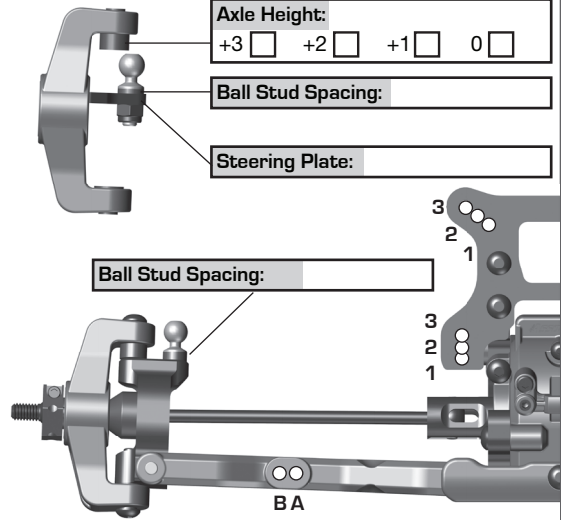

Rear Suspension:

Ride Height: _____
 Camber: _____
 Anti-Roll Bar: _____
 Arm Type: _____
 Wheelbase Shim: _____
 Wheel Hex: _____
 CVA Bone Length: _____
 Chassis Brace: Plastic Carbon
 Hub Spacing: Fwd Mid Back
 Notes: _____

Rear Chassis Brace Screws: _____

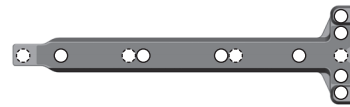

Arm Mount C: 1° 0.5°



Arm Mount D: 1° 0.5°

Diff Height:

+3

+2

+1

0

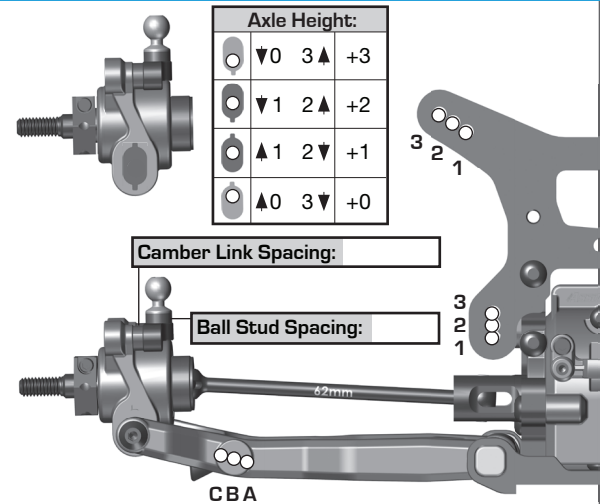

Electronics:

Radio: _____ Servo: _____
 EPA: Throttle: _____ % Brake: _____ %
 ESC: _____
 ESC Settings: _____
 Motor: _____
 Wind: _____ Timing: _____
 Pinion: _____ Spur: _____
 Battery: _____
 Battery Position: _____

Differential:

Front Fluid: _____ Mass: _____
 Gears: Plastic Metal
 Center Fluid: _____ Mass: _____
 Gears: Plastic Metal
 Rear Fluid: _____ Mass: _____
 Gears: Plastic Metal
Slipper Clutch:
 Setting: _____
 Pads: _____

Shocks:

	Front	Rear
Piston:		
Fluid:		
Spring:		
Limiters:		
Stroke:		
Eyelet Length:		
Cup Offset:		
Notes:		

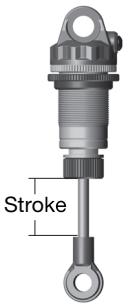

Track Info:

Size: Small Medium Large Extra Large
 Surface: Dirt Carpet AstroTurf Multi Surface
 Traction: Low Medium High Very High
 Moisture: Dry Damp Wet
 Condition: Indoor Outdoor Dusty Hard Packed
 Bumpy Grooved Smooth Loamy
 Temperature: Ambient: _____ Track: _____
 Notes: _____

Tires:

Front Tires: _____
 Front Compound: _____
 Front Insert: _____
 Rear Tires: _____
 Rear Compound: _____
 Rear Insert: _____
 Wheel (F/R): _____
 Notes: _____

Body, Wing, Weight:

Body: _____
 Wing: _____
 Front Wing: Yes No
 Wing Angle: 0° 6°
 Weights: _____
 Total Vehicle Weight: _____

Vehicle Comments:

Notes: _____